

# MX-5 Cup Technical Bulletin 01-09



**To:** SCCA Pro Racing MX-5 Cup Participants  
**From:** Jim Jess, MX-5 Technical Manager  
Phone: Office: (785) 862-7157 Cell: (785) 554-7904  
E-Mail: jjess@sccapro.com  
**Date:** March 24, 2009  
**Regarding:** 2009 MX-5 Cup Pre-Season Rule Changes and Clarifications



**Effective Date:** IMMEDIATELY

## Please Note these Changes and Additions to the 2009 PRR

**Article 3.5.3.2: Series Fuel, Pg. 72:** The use of any gasoline other than the specified Sunoco fuel is strictly forbidden. Additives are not allowed. Any violation of this section may result in disqualification, loss of all points and money earned at that event, and a fine of up to \$10,000.00.

**Article 3.5.3.3: Series Fuel, Pg. 72:** Fuel will be tested as directed by the TECHNICAL MANAGER. When a fuel sample is drawn from the car, the sample must be the same color as the fuel supplied. Fuel will be tested utilizing the **Authentix LSX 1000** test system and/or any other method deemed appropriate by the TECHNICAL MANAGER. All fuel will be tested against the sample taken from the fuel supplied at the individual tracks. Although the fuel is very similar from batch to batch, it can vary some. Therefore, teams should use the fuel from the supplier at the track. The point of purchase of the fuel will be irrelevant as to whether a fuel passed the official fuel test, or not.

**Article 3.5.3.4: Series Fuel, Pg. 72:** Sunoco 260GTX must be used during **ALL** official sessions.

### Article 3.5.6: Cameras, Pg. 72:

In car video must be provided to series officials from every car, recording any time the car is on track in an official session.

Note: Penalties will be assessed for any of the following;

1. Video cards returned without video on them. (3.5.6)
2. Cameras aimed improperly (3.5.6.4)
3. Excessive camera vibration. (3.5.6.4)
4. No or Incorrect time/date stamp (3.5.6.1)

**It is the teams responsibility to ensure that the in car camera system functions properly.**

**3.5.6.1:** All vehicles must have a PDR-100 camera system from Chase Cam installed. Contact the Technical Department before ordering a camera to ensure the correct system is ordered. The PDR-100 must be wired to the vehicle's master electrical switch, such that the PDR-100 is supplied with power whenever the master electrical switch is turned on. An SS1000 split screen recording unit may also be used, allowing for two cameras to be recorded. The PDR-100 must be configured to record the time and date stamp. Time and Date **MUST** be properly configured for the event.

**3.5.6.2:** Teams shall provide the series officials with Two Compact Flash memory cards for use with the PDR-100. The memory cards shall be at least 16GB capacity and 133X speed. Teams will own their own memory cards, but the series will maintain possession of the two memory cards during the season.

**3.5.6.3:** At the beginning of an event the series officials will provide teams with one blank memory card for their cars. During any official session, each car must have the correct memory card installed in the PDR-100, with the PDR-100 recording onto the card any time the car is on track. All official sessions must be recorded on one memory card. Series officials may view the video at anytime during the event. The memory card must be dropped off at the series transporter within 60 minutes of the end of the race.

Teams may copy the contents of the memory card during this 60 minute period, but shall not alter the contents of the card in any way.

**3.5.6.4:** The primary camera shall be pointed forward, in a position that allows it to record the track ahead of the car. The camera shall record objects at heights ranging from 22 inches to 52 inches, 60 inches from the front of the car.

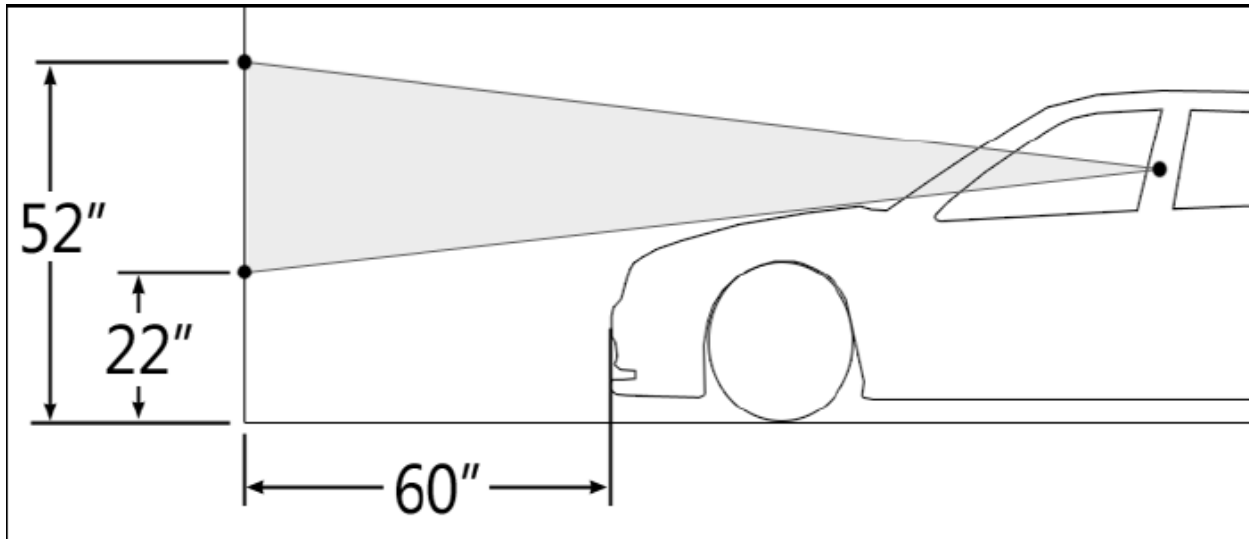

Series officials may have a monitor and measuring equipment available to check the positioning of cameras.

Cameras must be mounted such that they do not vibrate excessively while the car is on track.

Cameras must be mounted right side up, such that the recording is not upside down or sideways. All cameras and recording units must be mounted rigidly to the car such that they will withstand a sustained 25-G deceleration.

**3.5.6.5:** The video provided to series officials must record the movement of the vehicle's steering wheel. This must be accomplished in one of two ways. The primary camera may be positioned such that it records the steering wheel, in addition to meeting the requirements in article 3.6.5.4. Alternatively a secondary camera may be used which records the steering wheel, in which case the primary camera is not required to record the steering wheel.

# MX-5 Cup Technical Bulletin 01-09



**3.5.6.6:** The first character in the name of the files generated by the PDR-100 must indicate the class of the car, M for MX-5. For cars with two digit car numbers, the second and third characters shall be the car number. For cars with one digit car numbers, the second character shall be the letter 'X', and the third character shall be the car number.

Examples:	Car Class	Car Number	First three characters of file names
	M	65	M65
	M	2	MX2

**3.5.6.7:** Pro Racing may have a limited number of video systems available for rent during an event. Rental systems will include the PDR-100, a camera, and the two required memory cards, along with some mounting hardware. Contact the Technical Department for pricing.

**Article 3.5.8: Sound Levels, Pg. 72:** An exhaust sound decibel limit of 94 dBA will be in effect for all MX-5 Cup events. Sound levels will be measured with the vehicle stationary. A microphone will be placed 533mm (21in) off the ground, seven feet from the exhaust outlet, at a 45 degree angle to the outlet in the horizontal plane. The vehicle's engine speed will be held constant at 4500 RPM while the sound measurement is taken.

**Article 3.5.10: Engine Supply / Sealing, Pg. 73:** For 2009, ONLY Comptech sealed engines will be eligible. Engines must be ordered through Mazdaspeed. **Competitor rebuilt engines are prohibited.** Sealed engines may be returned to Comptech for service and resealing. **Engines returned to Comptech unsealed will be refused.**

**Article 3.6.1: Engine Modifications, Pg. 74:** Crankshaft Position Sensor and Crankshaft pulley relationship MUST be as specified in the 2006~2009 MX-5 Factory service manual, CRANKSHAFT POSITION (CKP) SENSOR INSPECTION [LF] Pg. 01-40-34

**Article 3.6.1.4: Fuel System, Pg. 74:** Unleaded fuel filler trap door and restrictor plate in filler neck may be removed. **An FIA approved dry break must be installed between the rigid fuel supply line and the fuel rail per Appendix M.**

**Article 3.6.1.5: Clutch, Pg. 74:** The Clutch disc and Pressure plate must be bolted directly to an Unmodified stock flywheel. Allowable Clutch Components are as follows:  
Clutch disc: Mazda p/n: LF04-16-460B or Mazdaspeed p/n: 0000-02-5415-AC or 0000-02-5416-AC  
Pressure plate: Mazda p/n: LF04-16-410A or Mazdaspeed p/n: 0000-02-5405-AC

Clutch disc:	Diameter - 8.5"	Weight - 1.7 lbs. min.
Pressure Plate:	Diameter - 9.875"	Weight - 9.4 lbs. min.
Flywheel:	Diameter - 11.0" (overall)	Weight - 16.0 lbs. min.
	Diameter - 9.375" (machined surface)	

**Article 3.6.2.1: Transmission/Final Drive, Pg. 75:** The stock 2006~2009 6-speed gearbox, internal parts and ratios shall be used by all cars. Mazdaspeed 3-4 shift fork (P/N 0000-02-5701) is allowed. The gearbox is a team serviceable part.

# MX-5 Cup Technical Bulletin 01-09



**Article 3.6.3.9: Front Hubs, Pg. 76:** RX8 front hubs may be substituted in place of the O.E. hubs. To complete the conversion, the following parts may be purchased from Mazdaspeed Motorsports Development: Front Hub #F151-33-04X, ABS Adaptor #0000-03-5901, special installation tool# 0000-03-5902. Or F189-33-04X may be used

**An "L" shaped retainer is allowed for the ABS adaptor housing provided it serves no other purpose.**

**Article 3.6.3.10: Front Uprights, Pg. 76:** Only Stock, Unmodified 2006 -2008 front uprights are allowed. 2009 uprights are NOT approved.

**Article 3.6.5.1: WHEEL/TIRE SPECIFICATIONS, Pg. 76:** All wheels shall be one of the three OE Mazda Miata 17"x7" wheels.

Style 1: (p/n: 9965-38-7070) Style 2: (p/n: 9965-36-7070) Style 3: (p/n: 9965-45-7070)

Note: All styles of wheels cost and weigh the same.

**Article 3.6.4.3: Brake Pads, Pg. 76:** Any Brake Pads that fit the stock, unmodified caliper are approved

**Article 3.6.5.3: Official Series Tire, Pg. 77: TBA**

**Article 3.6.6: Body Modifications, Pg. 77:** MX-5 Cup cars may be fitted with 2006~2008 or 2009 bodywork. 2009 Bodywork will be required at a date TBA during the 2009 season. Please contact Tim Buck at Mazdaspeed (800-435-2508) for required part #s

**Article 3.6.6.4: Body Modifications, Pg. 77:** Hood pins are permitted. If hood pins are fitted, the OE latch **MAY** be removed.